

HORIZONTAL BALERS

Gemini®

Manual-Tie Horizontal Baler



Gemini® 3560 Pictured



Gemini® Series Features

- ▼ Process a variety of materials such as PET, aluminum or steel cans, paper, plastics, OCC, newsprint, and more
- ▼ Hydraulic bale-door release
- ▼ Available in various feed hoppers, such as “Hand Feed”, Chute Feed, etc.
- ▼ Customizable for your application

The Worldwide Leader in Quality Recycling and Compaction Equipment

Marathon® Equipment is known throughout the world as one of the leading manufacturers of quality on-site recycling products. The **Marathon** brand has been the industry standard for quality and innovation for more than 50 years, and includes auto-tie balers, manual-tie balers, two-ram balers, MRF systems, conveyors, vertical balers, auger-style compactors, cart dumpers, and a wide array of options for virtually any application.



**Environmental
Solutions Group®**

a **DOVER** company

HORIZONTAL BALERS



Gemini® Horizontal Baler

Features



Gemini® 3560 Pictured

Gemini® Horizontal Baler Standard Features

- ▼ Full-penetration ram for maximum compaction and full-bale ejection
- ▼ Reversible and adjustable bolt-in shear blade (Gemini® Xtreme only)
- ▼ Twin cross cylinders with 20 HP motor
- ▼ 34-second cycle time
- ▼ Wire guides for quick and easy ties
- ▼ Hopper access door with interlock and viewing port
- ▼ Nylon runners for smooth ram operation
- ▼ Totally enclosed, fan-cooled (TEFC) motor for worry-free operation

Gemini® Horizontal Baler Optional Features

- ▼ Optional above floor or pit variable-speed conveyor



Gemini® Xtreme with Conveyor pictured

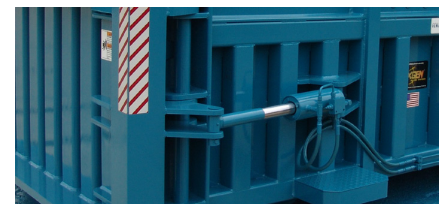

Hydraulic Door Latch

Marathon® Gemini Series balers feature an hydraulic door latch



Touch Screen

The touch screen enables full automatic and manual control with one touch. Screens may be customized, password protected, and are designed with alarm, diagnostic, and help screens.



Power Unit

High-efficiency power unit with horsepower limited, pressure compensated piston pump.





- Transfer Compactors
- Horizontal Balers
- Conveyors

MARATHON WARRANTY

The best coverage in the business

Marathon® Equipment is pleased to announce the release of our updated Warranty Coverage program. This warranty will take effect and be applicable on all products sold on or after June 1st, 2021. Note that this warranty plan is not retroactive to products sold prior to June 1st, 2021.

5 Yr. Structural, 1 Yr. Parts, 1 Yr. Labor

Marathon® Compactor & Recycling Solutions Warranty

Our existing Signature Series® Warranty, Compactor Warranty, and Auger Warranties have been combined into a new Compaction Solutions Warranty. The Compaction Solutions Warranty includes 3-years structural warranty, 2-years part warranty, and 1-year labor warranty.

To learn more, visit: www.marathonequipment.com/warranty



Connected Collections™

1 BACK-OF-STORE CONNECTED ASSET SOLUTIONS



1 Focus on the front of the store, we've got the back.

The ultimate solution for peace of mind, efficiency, and productivity.

2 Marathon® provides a full suite of value-added needs.

New and Marathon Certified Remanufactured compactors and balers, digital connectivity, and waste stream monitoring to minimize your waste-related expenses and maximize recycling revenue.

Digital connectivity enables asset monitoring, assists with predictive maintenance, and connection to hauler operations.

Partnership with Marathon® supports your long-term sustainability objectives - and provides documentary evidence of your performance.

3 All the information you need at the tips of your fingers.

Eye-Site™ provides a complete dashboard view of the waste and recycling programs for your entire enterprise.

HORIZONTAL BALERS



Gemini[®] Horizontal Baler

Dimensions & Specifications

Specifications	Gemini [®] 3560	Gemini [®] Xtreme
Nominal Bale Size (H x L x W)	30" x 48" x 60" 762mm x 1219mm x 1524mm	
Baler Weight	12,000 lbs. 5443 kg	17,600 lbs. 7983 kg
Performance Characteristics		
Standard Operating Pressure	2,450 psi 169 bar	3,000 psi 207 bar
Platen Force	120,000 lbs. 54431 kg	147,300 lbs. 66814 kg
Platen Pressure	68 psi 469 kPa	81.8 psi 564 kPa
Cycle Time (partial penetration)	34 seconds	
Bale Weight (OCC)	Up to 1,250 lbs. 567 kg	Up to 1,400 lbs. 635 kg
Electrical Equipment		
Electric Motor 460 / 3-Phase	20 hp / 15 kW	
Electric Control Voltage	120 VAC	
Hydraulic Equipment		
Pump Capacity	34 gpm / 129 L/min	
Reservoir	100 gal. / 379 L	
Hydraulic Cylinder(s)	2	
Bore	6" / 152mm	
Rod	4" / 102mm	
Stroke	57" / 1448mm	

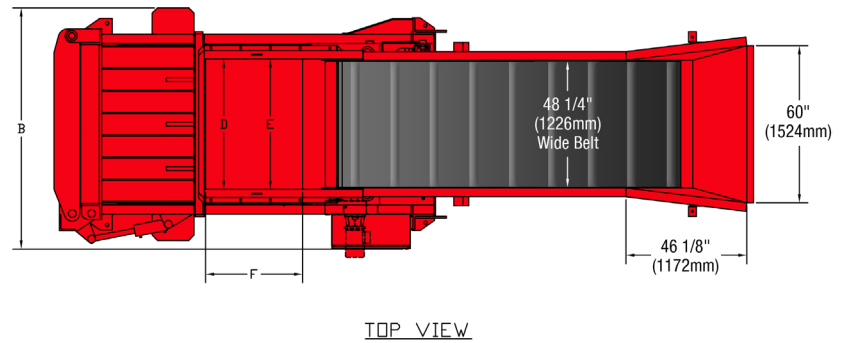
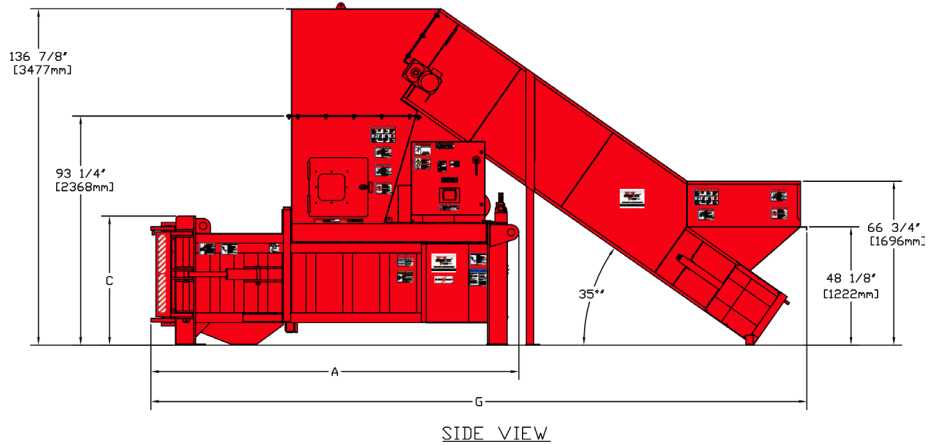

Dimensions	(A) Structural Length	(B) Structural Width	(C) Body Height	(D) Charge Chamber Width	(E) Clear Top Width	(F) Clear Top Length	(G) Structural Length With Conveyor
Gemini[®] 3560	147 1/4"	86 7/8"	51 1/8"	60"	57"	35"	267 5/16"
	3740mm	2207mm	1299mm	1524mm	1448mm	889mm	6790mm
Gemini[®] - Xtreme	157 1/4"	89 15/16"	49 1/2"	60"	55 3/4"	35 3/8"	266 15/16"
	3994mm	2284mm	1257mm	1524mm	1416mm	899mm	6780mm

Pictures and mechanical diagrams in this literature are illustrative only and may not be to scale. Specifications are subject to change without notice in order to accommodate improvements to the equipment. Certified in compliance with ANSI standard Z245.2 and all applicable OSHA Regulations. Products must be used only by trained operators in accordance with the Operator Manual, as well as applicable regulations, laws, and ANSI standards.

We're Here To Help!

For detailed specifications, recommendations, or to request a site survey comparing various systems, contact the Marathon[®] Sales Team at MarathonSales@MarathonEquipment.com

Authorized Dealer:



Marathon Equipment Company | P.O. Box 1798 | Vernon, AL 35592-1798

Learn more about Marathon Equipment: 800.633.8974 | www.marathonequipment.com