

SELF-CONTAINED COMPACTORS

DRC II

Dual-Recycling Compactor



DRC II Features

- ▼ Two compartments segregate waste and recyclables, increasing your return on the sales of recycled materials
- ▼ Two compactors in one
- ▼ Neat and attractive appearance
- ▼ Excellent for applications where recycling is required but there is only room for one compactor

The Worldwide Compaction Leader

Marathon® Equipment is known throughout the world as one of the leading manufacturers of quality on-site waste compaction products. The RamJet® brand has been the industry standard for quality and innovation for more than 50 years, and includes stationary and self-contained compactors, compaction containers, apartment and high-rise compactors, pre-crushers, auger-style compactors, transfer systems, and a wide array of options for virtually any application.



**Environmental
Solutions Group®**

a DOVER company

DRC II Dual-Recycling Compactor

Overview

Perfect for:



Hospitals/Institutions



Restaurants



Manufacturing Plants



Malls / Shopping Centers



Retail Stores



High-Rise Office Buildings

Why Marathon® Equipment is the Preferred Choice

Marathon components are selected for longevity and minimum maintenance, with special attention given to the selection of high-duty cycle components. Stress engineering provides the optimum degree of structural integrity. Only the best materials are used, and the highest standards of quality are observed in the manufacturing process.

Our RamJet® units are state-of-the-art in roll-off self-contained compactors, featuring large feed openings, and expanded container storage capacity. They are designed to optimize safety for workers, store and transport your waste, prevent contamination of public areas in accordance with public health department requirements, improve working conditions for your employees, and reduce disposal costs.

The DRC II Two Compartment, Dual-Purpose Compactor

The DRC II is one dual-purpose compactor, occupying one space, with two separate compartments that enable you to compact a wide range of waste and recyclables all at one time.

Unlimited Compaction Combinations with the DRC II:

- ▽ Garbage and Corrugated
- ▽ Corrugated and High-Grade Paper
- ▽ Paper and Aluminum Cans
- ▽ Garbage and Co-Mingled Recyclables

▽ Increase Your Return

Two separate compartments segregate waste and recyclables, which increases your return on the sale of recycled materials.

▽ Two Compactors in One

Separate, compact, and process two different materials, such as recyclables and garbage, at the same time in an area where space permits only one compactor.

▽ Neat and Attractive Appearance

Both recyclables and garbage are neatly contained after compaction, providing your building, facility, mall, or store with a neat and attractive appearance.



SELF-CONTAINED COMPACTORS



DRC II Dual-Recycling Compactor

A New Dimension in Recycling

Marathon® Flex-D-Vider®

Creates Two Variable-Capacity Compartments

The DRC II has a total capacity of 28 cubic yards. The two variable-capacity compartments are separated by a 24" high, solid-welded barrier. This barrier wall prevents liquid from leaking from one side to the other.

The DRC II accepts and compacts unequal and unpredictable volumes of two separate discardables.

This is made possible by the patented **Marathon Flex-D-Vider**, a pivoting steel wall that adjusts the compartments' capacities during the loading and packing process. For easier discharge of the materials in the smaller compartment, a hydraulic cylinder enables the operator to move the **Marathon Flex-D-Vider** to the vertical

center of the container, relieving the pressure on the remaining waste or recyclables. Each compartment when loaded, can represent as little as 30% or as much as 70% of the unit's total volume. The DRC II can also be chute-fed to increase customer security and reduce labor costs.

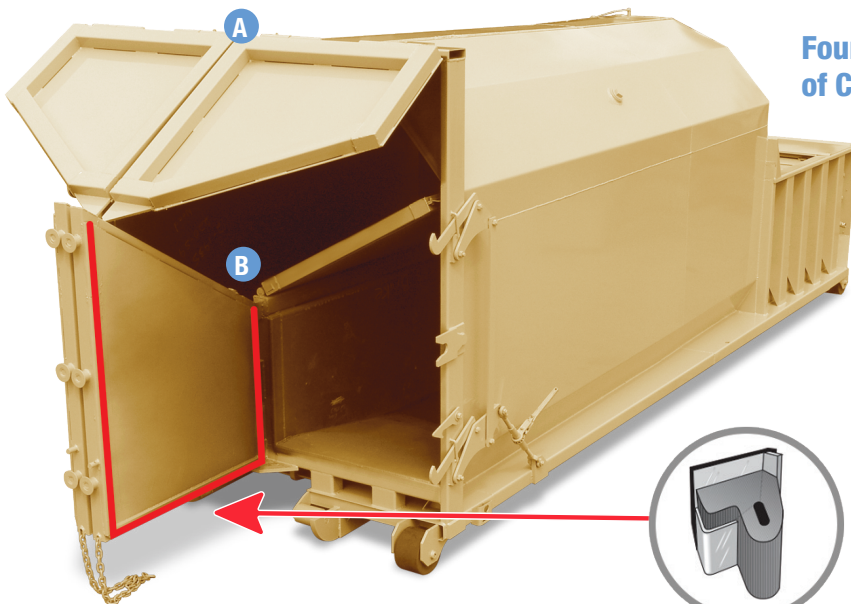
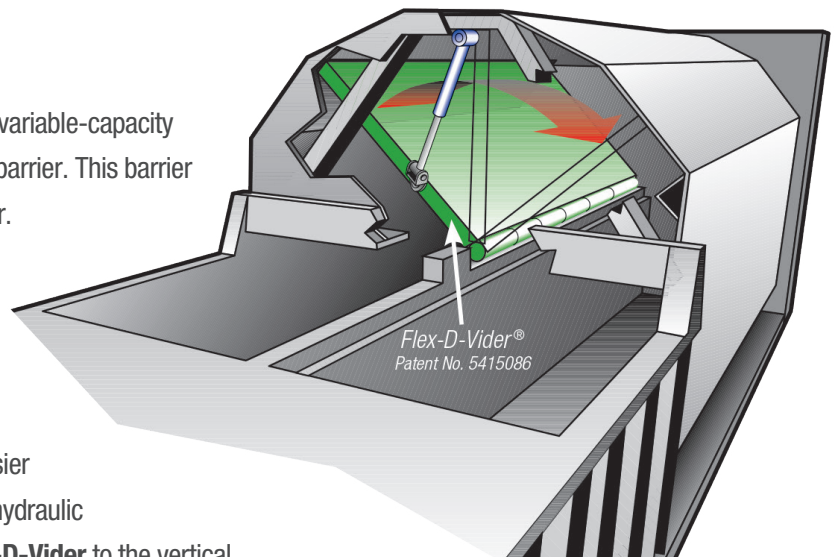

Four Individual Doors for Controlled Discharge of Compacted Material

Due to the many variable positions in which the **Marathon Flex-D-Vider** can be located, four individual doors are used for the discharge of materials.

- A** Upper doors are top-hinged and have ratchet locks that enable the door to be opened independently of the lower doors.
- B** Lower doors are hinged in the center of the container. Each door is equipped with the standard ratchet latch and opens independently for controlled discharge of compacted material.

P-Seal Watertight Door Gasket

P-Seal Watertight Closure

For wet waste applications, an optional door gasket is available with the custom designed **Marathon P-shaped door seal**, developed specifically for self-contained compactors used for wet waste. Either or both sides may be gasketed.



SELF-CONTAINED COMPACTORS



DRC II Dual-Recycling Compactor

Features and Available Options

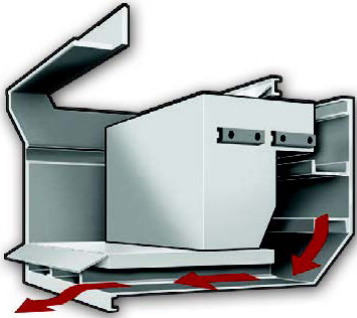

Qwik Clean® Tank

The **Qwik Clean** Tank with exclusive Trash Check™ is a standard feature on the DRC II. It funnels any liquid seepage occurring during compaction into an enclosed area underneath the charge box floor. The liquid is automatically discharged at the disposal site, in effect flushing the container and the area behind the ram.



Remote Power Pack

Separate from the compactor/container, the Marathon® brand Remote Power Pack remains free of damage caused while hauling to and from disposal sites, and stays free of problems caused by landfill dust. There are no electrical connections to make or break, and two simple-to-use, hydraulic quick disconnects couple the power unit to the packing head. All **Marathon** Remote Power Packs are built in-house to our quality standards, and each unit must pass a series of stringent tests before it can be shipped with the selected compactor.



Optional Doghouse and Chute Options

The Dual-Recycling Compactor can be fitted with a variety of optional equipment such as through-the-wall security chutes and lockable doghouse hoppers. The DRC II is well suited for ground, doghouse, dock, or chute feed applications. Doghouses may be rear- or side-feed, or both.



Available with Bayne Thinline® Cart Lifter

If equipped with an optional integral cart lifter, the DRC II offers an economical and safety-conscious solution for a wide variety of waste material handling applications.

Bayne Thinline® cart lifters work with standard two-bar roll-out carts and can lift up to 750 lbs. Lifter has a powder-coated finish so it can stand up to the elements and be easily cleaned.



Cycon Life-Xtender™ Cyclic Control System

Standard on all DRC II Self-Contained Compactors

- ▼ Reliable, solid-state circuitry eliminates all pressure and limit switches
- ▼ The **Cycon Life-Xtender** no-shock cycle control extends cylinder and hose wear life
- ▼ Automatic “container full assurance system” — the ram dwells against the load at full pressure, resulting in better compaction
- ▼ Smoother running, quieter operation
- ▼ Advanced hydraulic design enables the system to operate at minimum pressure levels until the need for more pressure is automatically sensed
- ▼ More accurate Advanced Warning or Container Full options
- ▼ Dramatically improved cold-weather performance





- Self-Contained Compactors
- TC Tanks
- Stationary Compactors
- Auger Compactors
- Containers & Carts
- VIP
- MPT
- Mini-Mac
- VB
- Cart Dumpers

MARATHON WARRANTY

Marathon® Equipment is pleased to announce the release of our updated Warranty Coverage program. This warranty will take effect and be applicable on all products sold on or after June 1st, 2021. Note that this warranty plan is not retroactive to products sold prior to June 1st, 2021.

Marathon® Compaction Solutions Warranty

3 Yr. Structural, 2 Yr. Parts, 1 Yr. Labor

Our existing Signature Series Warranty, Compactor Warranty, and Auger Warranties have been combined into a new Compaction Solutions Warranty. The Compaction Solutions Warranty includes **3-years structural warranty, 2-years part warranty, and 1-year labor warranty.**

Worry-Free, Lowest Life-Cycle Cost

You have great options for equipment acquisition. Choose from a new Marathon® compactor or baler, or get a Marathon Certified Remanufactured product backed by the same best-in-industry warranty of a new Marathon product.

Our multiple extended warranty options, preventive service and maintenance programs, OEM parts, and asset connectivity all combine to optimize the performance of your equipment.

Digital connectivity monitors your assets ensuring predictive and condition-based equipment maintenance. Eliminate the costs associated with unnecessary down time and repairs. Service only when needed and replace only when and what is needed.

GOT CORES? TRADE IN - TRADE UP!

Through our **Marathon** Certified Remanufactured compactor and baler program, you can now establish a true closed-loop recycling process, which not only includes your commodities, but also your equipment.

The **Marathon** Certified Remanufacturing program allows you to purchase a factory-certified remanufactured product with the same warranty as a brand new one, providing a solution to optimize recycling commodities AND equipment.

For more information on the Marathon Cores Program, contact your local dealer.





Connected Collections™

1 BACK-OF-STORE CONNECTED ASSET SOLUTIONS



1 Focus on the front of the store, we've got the back.

The ultimate solution for peace of mind, efficiency, and productivity.

2 Marathon® provides a full suite of value-added needs.

New and Marathon Certified Remanufactured compactors and balers, digital connectivity, and waste stream monitoring to minimize your waste-related expenses and maximize recycling revenue.

Digital connectivity enables asset monitoring, assists with predictive maintenance, and connection to hauler operations. Partnership with Marathon® supports your long-term sustainability objectives - and provides documentary evidence of your performance.

3 All the information you need at the tips of your fingers.

Eye-Site™ provides a complete dashboard view of the waste and recycling programs for your entire enterprise.

BEST BRAND. UNMATCHED CUSTOMER VALUE. ALL EYES ON YOUR BUSINESS.

Asset Management

- Availability and predictability of assets
- Preventative Maintenance & Service Agreements
- Extended Warranty options
- OEM Parts
- Marathon Certified Remanufacturing with the same warranty as new

Waste Metering

- Right product in the right bucket
- Traceability and control of recycling material
- Enterprise tracking for sustainability goals and measurement
- Reduce contamination

Productivity

- Ensure you have the right equipment
- Pick up when full and not early. Minimize disposal costs
- Remote fullness monitoring & bale weight monitoring
- Maximize recycling revenue

SELF-CONTAINED COMPACTORS



DRC II Dual-Recycling Compactor

Dimensions & Specifications

Specifications		
Clear Top Opening	34 1/2" x 48"	876mm x 1219mm
Capacity per Hour (total)	165 yd ³	126 m ³
Weight	16,000 lbs.	7258 kg
Performance Characteristics		
Cycle Time	39 seconds	
Total Maximum Force	31,800 lbs.	141 kN
Maximum Ram-Face Pressure	18.7 psi	129 kPa
Ram Penetration	6 1/2"	165mm
Electrical Equipment		
Electric Motor 3/60/230-460	10 hp	7.5 kW
Electric Control Voltage	120 VAC	
Panel Box Assembly		
All Circuits Fused	3-Button Controls: Keylock Start, Stop, Reverse	
Hydraulic Equipment		
Hydraulic Pump Capacity	10 gpm	38 L/min
Normal Pressure	2,000 psi	138 bar
Hydraulic Cylinder - Bore	4 1/2"	114mm
Hydraulic Cylinder - Rod	2 1/2"	64mm
Hydraulic Cylinder - Stroke	55 1/2"	1410mm

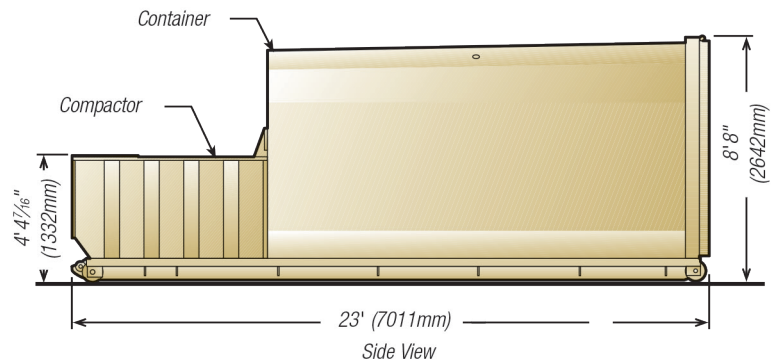
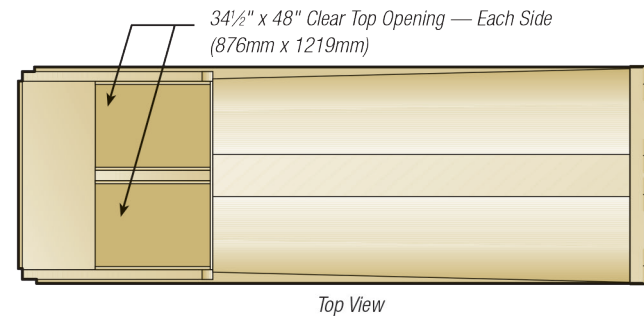
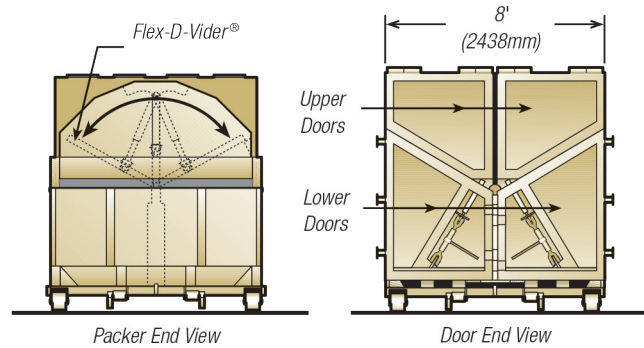

Pictures and mechanical diagrams in this literature are illustrative only and may not be to scale. Specifications are subject to change without notice in order to accommodate improvements to the equipment. Certified in compliance with ANSI standard Z245.2, all applicable OSHA Regulations. Products must be used only by trained operators in accordance with the Operator Manual, as well as applicable regulations, laws, and ANSI standards.

We're Here To Help!

For detailed specifications, recommendations, or to request a site survey comparing various systems, contact the Marathon® Sales Team at MarathonSales@MarathonEquipment.com

Authorized Dealer:



Marathon Equipment Company | P.O. Box 1798 | Vernon, AL 35592-1798

Learn more about Marathon Equipment: 800.633.8974 | www.marathonequipment.com



www.marathonequipment.com

Contact your Marathon® authorized dealer: