

Side-Eject Horizontal Baler



Side-Eject Features

- ▼ Switch recyclables without contamination and maximize the value of your product
- ▼ Minimize spillage between bales and reduce the need to “double handle” materials
- ▼ Remove finished bales quickly and automatically to improve efficiency
- ▼ Front bale tie off saves valuable floor space and eliminates trips behind the baler

The Worldwide Leader in Quality Recycling and Compaction Equipment

Marathon® Equipment is known throughout the world as one of the leading manufacturers of quality on-site recycling products. The **Marathon** brand has been the industry standard for quality and innovation for more than 50 years, and includes auto-tie balers, manual-tie balers, two-ram balers, MRF systems, conveyors, vertical balers, auger-style compactors, cart dumpers, and a wide array of options for virtually any application.



**Environmental
Solutions Group®**

a DOVER company

Side-Eject Horizontal Baler

Overview



The Marathon[®] patented line of Side-Eject Horizontal Balers are uniquely engineered to maximize productivity. They include many features not found on conventional closed-end balers.

Key Features

- ▼ Increased product value by eliminating contamination between bales as the operator changes materials being processed.
- ▼ Dramatically reduces spillage commonly found with conventional balers. No need to “double handle” materials being processed.
- ▼ Maximum and consistent bale weights with the **Marathon** Bale Made Indicator, which signals that the bale is finished. No time consuming “flag pole” or manual measuring device to compromise bale quality.
- ▼ Remove each bale from the bale chamber quickly and easily with the patented **Marathon** Side-Eject feature and Bale Server Island. Unlike conventional balers that require an operator and forklift to free the bale from the end of the bale chamber, the **Marathon** Side-Eject design provides consistent and complete bale ejection every time.
- ▼ The **Marathon** exclusive front bale tie-off system allows the operator to quickly direct tie wires around the bale from the front of the baler. This eliminates the need to go behind the baler and loosen hanging wires that drag as a bale is made.

Side-Eject Horizontal Baler

Features and Benefits

Innovative Marathon[®] Features



The chute feed hopper with inspection door and interlock switch will accommodate optional pneumatic, gravity, or conveyor feeding systems.



The advanced **Marathon** power pack is designed so that all of the valves are contained in a single manifold, which minimizes the number of hose connections and potential leak sources.

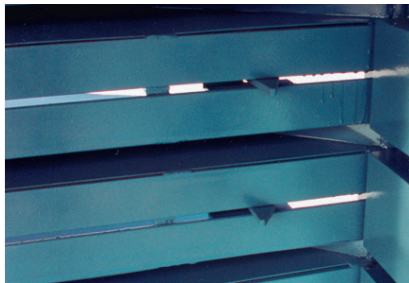

Spring-loaded container dogs are located on each side of the bale chamber to produce superior spring back control of materials being processed.

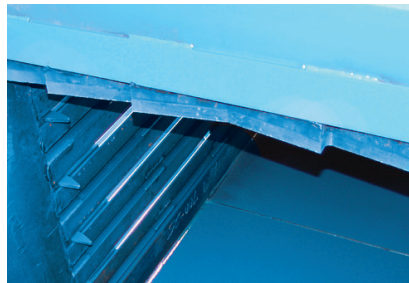

Bolt-on adjustable and replaceable shear blades cut material as a bale is made, and minimize problems associated with irregular bales sizes. This makes bales easier to tie and stack.



Marathon Side-Eject Balers feature an hydraulic door latch, standard on all models.

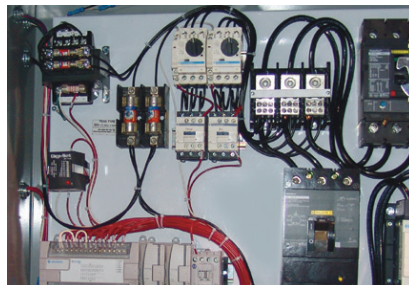

The programmable controller allows for customized programs to better meet customer needs. The controller eliminates the need for relays and timers that take up valuable panel space. All electrical components are UL and CUL listed.

Marathon[®] Patented Automatic Side-Ejection Features Seamless Push Button Operation

Pressure is relieved from the bale in three directions to achieve positive and complete bale ejection from the chamber.

This advanced method of bale ejection begins by activating the “Home” button, which causes the platen to retract to a pre-set location relieving the end force on the bale. The operator then opens the chamber door, which relieves side force and automatically unlocks the hinged upper section of the chamber to relieve vertical force on the bale.

With pressure on the bale effectively relieved from all directions, an hydraulic-powered Server Island, located on the floor of the bale chamber, quickly and completely pushes the bale out of the chamber. The Server Island functions as a pallet, eliminating costly construction of permanent guide islands. After the bale is removed with a forklift or pallet jack, the Server Island is retracted—saving valuable space.

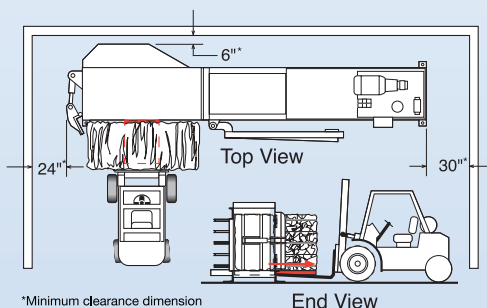

Space-saving design

Install a **Marathon** Side-Eject Baler close to a wall or in a tight space. Minimal floor space is needed for operation due to the unique front baler tie-off feature and side-eject design.

Side-Eject Horizontal Baler

Dimensions and Specifications

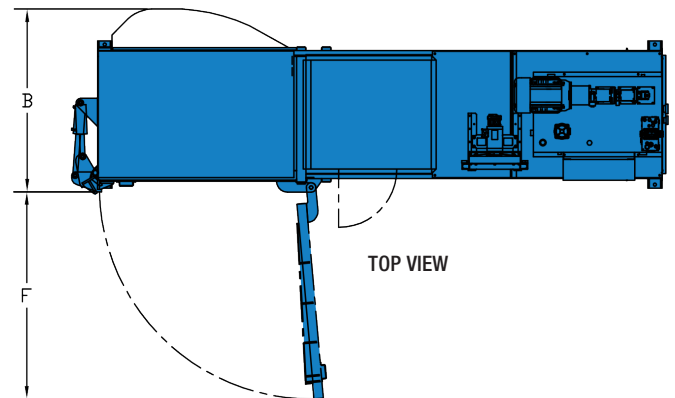
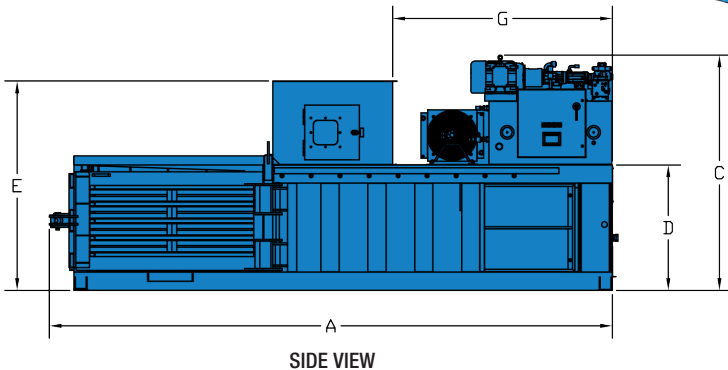

Side-Eject Horizontal Baler Dimensions

Specifications	A	B	C	D	E	F	G
SE-503042-720	21' 4" 6502mm	60" 1524mm	103 1/2" 2629mm	55 3/16" 1402mm	92" 2337mm	87" 2210mm	97" 2464mm
SE-503042-830	21' 4" 6502mm	60" 1524mm	103 1/2" 2629mm	55 3/16" 1402mm	92" 2337mm	87" 2210mm	97" 2464mm
SE-504242-830	21' 4" 6502mm	70 1/16" 1795mm	103 1/2" 2629mm	55 3/16" 1402mm	92" 2337mm	87" 2210mm	97" 2464mm
SE-504842-830	21' 4" 6502mm	76 3/4" 1949mm	103 1/2" 2629mm	55 3/16" 1402mm	92" 2337mm	87" 2210mm	97" 2464mm
SE-604842-830	23' 1" 7036mm	76 1/16" 1948mm	103 1/2" 2629mm	55 3/16" 1402mm	92" 2337mm	87" 2210mm	97" 2464mm
SE-504242-950	21' 1" 6426mm	71" 1803mm	103 1/2" 2629mm	55 3/16" 1402mm	92" 2337mm	87" 2210mm	97" 2464mm

Pictures and mechanical diagrams in this literature are illustrative only and may not be to scale. Specifications are subject to change without notice in order to accommodate improvements to the equipment. Certified in compliance with ANSI standard Z245.2 and all applicable OSHA Regulations. Products must be used only by trained operators in accordance with the Operator Manual, as well as applicable regulations, laws, and ANSI standards.



- Transfer Compactors
- Horizontal Balers
- Conveyors

MARATHON WARRANTY

Marathon® Equipment is pleased to announce the release of our updated Warranty Coverage program. This warranty will take effect and be applicable on all products sold on or after June 1st, 2021. Note that this warranty plan is not retroactive to products sold prior to June 1st, 2021.

Marathon® Compactor & Recycling Solutions Warranty **5 Yr. Structural, 1 Yr. Parts, 1 Yr. Labor**

Our existing Signature Series® Warranty, Compactor Warranty, and Auger Warranties have been combined into a new Compaction Solutions Warranty. The Compaction Solutions Warranty includes 3-years structural warranty, 2-years part warranty, and 1-year labor warranty.

Worry-Free, Lowest Life-Cycle Cost

You have great options for equipment acquisition. Choose from a new Marathon® compactor or baler, or get a Marathon Certified Remanufactured product backed by the same best-in-industry warranty of a new Marathon product.

Our multiple extended warranty options, preventive service and maintenance programs, OEM parts, and asset connectivity all combine to optimize the performance of your equipment.

Digital connectivity monitors your assets ensuring predictive and condition-based equipment maintenance. Eliminate the costs associated with unnecessary down time and repairs. Service only when needed and replace only when and what is needed.



GOT CORES? **TRADE IN - TRADE UP!**

Through our **Marathon** Certified Remanufactured compactor and baler program, you can now establish a true closed-loop recycling process, which not only includes your commodities, but also your equipment.

The **Marathon** Certified Remanufacturing program allows you to purchase a factory-certified remanufactured product with the same warranty as a brand new one, providing a solution to optimize recycling commodities AND equipment.

For more information on the Marathon Cores Program, contact your local dealer.



Connected Collections™

1 BACK-OF-STORE CONNECTED ASSET SOLUTIONS



1 Focus on the front of the store, we've got the back.

The ultimate solution for peace of mind, efficiency, and productivity.

2 Marathon® provides a full suite of value-added needs.

New and Marathon Certified Remanufactured compactors and balers, digital connectivity, and waste stream monitoring to minimize your waste-related expenses and maximize recycling revenue.

3 Digital connectivity enables asset monitoring, assists with predictive maintenance, and connection to hauler operations.

Partnership with Marathon® supports your long-term sustainability objectives - and provides documentary evidence of your performance.

3 All the information you need at the tips of your fingers.

Eye-Site™ provides a complete dashboard view of the waste and recycling programs for your entire enterprise.

BEST BRAND. UNMATCHED CUSTOMER VALUE. ALL EYES ON YOUR BUSINESS.

Asset Management

- Availability and predictability of assets
- Preventative Maintenance & Service Agreements
- Extended Warranty options
- OEM Parts
- Marathon Certified Remanufacturing with the same warranty as new

Waste Metering

- Right product in the right bucket
- Traceability and control of recycling material
- Enterprise tracking for sustainability goals and measurement
- Reduce contamination

Productivity

- Ensure you have the right equipment
- Pick up when full and not early. Minimize disposal costs
- Remote fullness monitoring & bale weight monitoring
- Maximize recycling revenue

Side-Eject Horizontal Baler

Dimensions and Specifications

Specifications	SE-503042-720	SE-503042-830	SE-504242-830	SE-504842-830	SE-604842-830	SE-504242-950
Feed Opening (L x W)	50 1/2" x 27 3/4" 1283mm x 705mm	50 1/2" x 27 3/4" 1283mm x 705mm	50 1/2" x 39 3/4" 1283mm x 1010mm	50 1/2" x 45 3/4" 1283mm x 1162mm	60 1/2" x 45 3/4" 1537mm x 1162mm	50 1/2" x 39 3/4" 1283mm x 1010mm
Bale Length	72" 1829mm	72" 1829mm	72" 1829mm	72" 1829mm	72" 1829mm	72" 1829mm
Bale Width x Height	32" x 42" 813mm x 1067mm	32" x 42" 813mm x 1067mm	42" x 42" 1067mm x 1067mm	48" x 42" 1219mm x 1067mm	48" x 42" 1219mm x 1067mm	42" x 42" 1067mm x 1067mm
Bale Weight (OCC)	Up to 1,200 lbs. Up to 544 kg	Up to 1,300 lbs. Up to 590 kg	Up to 1,600 lbs. Up to 726 kg	Up to 1,800 lbs. Up to 816 kg	Up to 2,000 lbs. Up to 907 kg	Up to 1,800 lbs. Up to 816 kg
Unit Weights*	15,900 lbs. 7212 kg	16,000 lbs. 7257 kg	18,600 lbs. 8437 kg	20,300 lbs. 9208 kg	20,900 lbs. 9480 kg	25,000 lbs. 11340 kg
Performance Characteristics						
Cycle Time	21 seconds	20 seconds	20 seconds	20 seconds	22 seconds	21 seconds
Maximum Baling Force	125,700 lbs. 559 kN	125,700 lbs. 559 kN	125,700 lbs. 559 kN	125,700 lbs. 559 kN	125,700 lbs. 559 kN	159,000 lbs. 707 kN
Platen Pressure	73 psi 503.3 kPa	73 psi 503.3 kPa	73 psi 503.3 kPa	73 psi 503.3 kPa	64 psi 441.3 kPa	94 psi 648.1 kPa
Electrical Equipment						
Electric Motor 208/230/460/575 3-phase	20 hp 15 kW	30 hp 22 kW	30 hp 22 kW	30 hp 22 kW	30 hp 22 kW	50 hp 37 kW
Electric Control Voltage	120 VAC	120 VAC	120 VAC	120 VAC	120 VAC	120 VAC
Hydraulic Equipment						
Pump Type	Vane	Vane	Vane	Vane	Vane	Vane
Pump Capacity	50 gpm 189 L/min	75 gpm 284 L/min	75 gpm 284 L/min	75 gpm 284 L/min	75 gpm 284 L/min	94 gpm 356 L/min
Operating Pressure	2,500 psi 172 bar	2,500 psi 172 bar	2,500 psi 172 bar	2,500 psi 172 bar	2,500 psi 172 bar	2,500 psi 172 bar
Reservoir	150 gal. 568 L	150 gal. 568 L	150 gal. 568 L	150 gal. 568 L	150 gal. 568 L	200 gal. 757 L
Hydraulic Cylinder(s)	1	1	1	1	1	1
Bore	7" 178mm	8" 203mm	8" 203mm	8" 203mm	8" 203mm	9" 229mm
Rod	4 1/2" 114mm	4 1/2" 114mm	4 1/2" 114mm	4 1/2" 114mm	4 1/2" 114mm	6" 152mm
Stroke	68" 1727mm	68" 1727mm	68" 1727mm	68" 1727mm	78" 1981mm	78" 1981mm

*The baler foundation must be a minimum of 6" thick, 3,000 psi steel-reinforced concrete. It is recommended that the baler be positioned on a 3/4" steel foundation plate to prevent possible floor damage.

Pictures and mechanical diagrams in this literature are illustrative only and may not be to scale. Specifications are subject to change without notice in order to accommodate improvements to the equipment. Certified in compliance with ANSI standard Z245.2 and all applicable OSHA Regulations. Products must be used only by trained operators in accordance with the Operator Manual, as well as applicable regulations, laws, and ANSI standards.

We're Here To Help!

For detailed specifications, recommendations, or to request a site survey comparing various systems, contact the Marathon® Sales Team at MarathonSales@MarathonEquipment.com

Authorized Dealer:



Marathon Equipment Company | P.O. Box 1798 | Vernon, AL 35592-1798

Learn more about Marathon Equipment: 800.633.8974 | www.marathonequipment.com



www.marathonequipment.com

Contact your Marathon® authorized dealer: